

Installation and Maintenance Manual

Inset Fixtures

Preface



Please read carefully and understand the contents of this manual.

Failure to read the manual may result in serious injury or even death, or serious damage to equipment.

Make sure this manual is always accessible for all users and ensure you have read and understood the contents.

Copyright © TKH Airport Solutions 2024

All rights reserved for TKH Airport Solutions. No part of this publication may be reproduced, modified, stored in a retrieval system, or transmitted, by any means or in any form without the written permission of the copyright owner.

The content of this document is property of TKH Airport Solutions. Proprietary rights of TKH Airport Solutions B.V. or USE System Engineering Holding B.V. or their affiliated companies include the following: The specified (product) information herein and all related data and information are proprietary and confidential to TKH Airport Solutions B.V. or USE System Engineering Holding B.V. and are the subject of trade secrets and copy licensed from TKH Airport Solutions B.V. or USE System Engineering Holding B.V. The related data and information are provided in confidence, and all use, disclosure, copying, transfer and storage, except as authorized in the written License Agreement from TKH Airport Solutions B.V. or USE System Engineering Holding B.V. to the user, is strictly prohibited.

The English version of this document is the original version; this language version is verified by the manufacturer. All other language versions are translations of the original English language version.

Contents

Preface	
1 About this manual	5
1.1 Symbols Used.....	5
1.2 Storing the Manual.....	5
1.3 Limitations of the Document.....	5
1.4 Terms and Abbreviations.....	6
1.5 Trademarks.....	6
1.6 Liability and Warranty.....	6
1.7 Manufacturer Details.....	7
1.8 Document Information.....	7
2 Safety	8
2.1 Qualified Personnel.....	8
2.2 Intended Use.....	8
2.3 General safety rules.....	9
2.4 Electrical hazards.....	9
2.5 Transport and Storage.....	10
3 About the product	11
3.1 About CEDD.....	11
3.2 About the CEDD Inset Fixtures.....	11
3.2.1 Position in the CEDD AGL System System.....	11
3.2.2 CEDD Inset Fixtures: Parts.....	12
3.2.3 Specifications.....	12
3.2.4 Spare Parts.....	13
4 Inspection	14
5 Installation	15
5.1 Tools and materials needed.....	15
5.2 Installing a CEDD 8" fixture in an 8" shallow base.....	15
5.3 Installing a CEDD 8" fixture in a 12" shallow base.....	18
5.4 Installing a CEDD 12" fixture in a 12" shallow base.....	19
5.5 Checking the installation.....	21
6 Operation and Commissioning	22
7 Maintenance	23
7.1 Preventive maintenance.....	23
7.2 Corrective maintenance.....	23
7.2.1 Tools and materials needed.....	23
7.2.2 De-installing a CEDD 8" fixture.....	24
7.2.3 De-installing a CEDD 12" fixture.....	25
8 Troubleshooting	27
8.1 Visual fixture check.....	27
8.2 CEDD cable check.....	27
8.3 Ferrites and clamp check.....	28

9 Taking out of service.....30
9.1 Disposal..... 30

1 About this manual

This manual contains information about the installation, de-installation, maintenance and troubleshooting of the CEDD Inset Fixtures. It also contains guidance for taking the product out of service and its safe disposal.

1.1 Symbols Used

The following marking conventions are used in this manual to draw attention to specific topics or actions.



indicates a hazardous situation that, if not avoided, will result in death or serious injury.



indicates a hazardous situation that, if not avoided, could result in death or serious injury.



indicates a hazardous situation that, if not avoided, could result in minor or moderate injury.



is used in this manual to indicate a situation that could result in damage to property or equipment.

The following symbols are used on equipment and in this manual to warn of potential hazards:



Danger of electrical shock or arc flash. Failure to observe this warning will result in serious injury or death.



Warning or Caution: where this symbol is used on the equipment, it is mandatory to consult the manual to find out the nature of potential hazards and any actions which have to be taken to avoid them.

1.2 Storing the Manual

This manual is a part of your product. Store the manual in a location that can be easily accessed by personnel working on the product.

It is the responsibility of the company operating this equipment to ensure that its personnel is provided with a copy of this manual.

1.3 Limitations of the Document

TKH Airport Solutions reserves the right to revise this document without notification.

The data provided in this document is based on the most recent information at the time of publication. TKH Airport Solutions is continually seeking to ensure that its products are developed to the latest technological standards. As a result, it is possible that there may be some differences between the product and the information in this manual.

For further information regarding adjustment, maintenance or repair which is not described in this document, please contact the Customer Service department of TKH Airport Solutions.

The information in this document concentrates solely on use of the products as intended by the manufacturer.

1.4 Terms and Abbreviations

This document may include the terms and abbreviations as listed below.

AGL	Airfield Ground Lighting
CEDD	Contactless Energy and Data Distribution
EASA	European Aviation Safety Agency
HIRE	High Intensity Runway Edge
HPS	High Power System
ICAO	International Civil Aviation Organization
IEC	International Electrotechnical Committee
LED	Light Emitting Diode
NUID	Node Unique Identification

1.5 Trademarks

CEDD[®] is a registered trademark of USE System Engineering Holding B.V. in the European Union. Other product names mentioned may be trademarks of TKH Airport Solutions B.V., USE System Engineering Holding B.V., or their affiliated companies.

1.6 Liability and Warranty

TKH Airport Solutions cannot be held responsible for injuries or damage resulting from non-standard, unintended use, faulty or improper installation of its equipment, or failure to follow the instructions and safety guidelines in this manual. The safety of any system incorporating the Inset Fixtures is the responsibility of any site installation, commissioning, maintenance, and operational personnel using the system.

NOTICE Disregarding the safety instructions in this manual will result in the loss of warranty in case of damage.

Refer to the general TKH Airport Solutions Terms and Conditions document supplied with your sales order contract for a complete liability and warranty description.

1.7 Manufacturer Details

TKH Airport Solutions

Elektrostraat 17

7483 PG Haaksbergen

The Netherlands

P.O. Box 236

7480 AE Haaksbergen

The Netherlands

Telephone: +31 (0)53 5741456

info@tkh-airportsolutions.com

<http://www.tkh-airportsolutions.com>

For service requests, please contact the TKH Airport Solutions Customer Service department service@tkh-airportsolutions.com

1.8 Document Information

Name : 05 CEDD AGL Inset Fixtures Installation and Maintenance Manual 03-70025

Version : V1.2

Language : English (Original manual)



For the latest version of this document see <https://www.tkh-airportsolutions.com/airfield-products/> or scan

2 Safety

When performing installation, maintenance or service activities, always carry out these activities with the greatest caution to avoid injuries or damage to the CEDD Inset Fixtures. All activities may only be performed by qualified and authorized personnel (see below). It is the responsibility of those in charge of preparing and/or supervising such work to take the necessary actions to ensure safe working conditions.

Always work safely and comply with procedures, regulations and local standards. If any of the warnings or safety requirements in this document are in conflict with existing local regulations, then the strictest regulation must take precedence.

Thoroughly read and observe all safety instructions in this document.

⚠ WARNING Disregarding the safety instructions in this manual could result in serious injury or death.

2.1 Qualified Personnel

Only qualified and authorized personnel are allowed to install, operate or maintain this equipment.

The term "qualified personnel" is defined here as individuals who thoroughly understand the equipment and its safe installation, operation or maintenance. Qualified personnel are physically capable of performing the required tasks, are familiar with all relevant and local safety rules and regulations, and have been trained to safely install, operate or maintain the equipment. It is the responsibility of the company installing, operating or maintaining this equipment to ensure that its personnel meet these requirements.

2.2 Intended Use

The CEDD Inset Fixtures are designed and intended only for the purpose Airfield Ground Lighting (AGL) at airfields and airports as described in this manual. Intended use also includes the observance of all procedures, inspection and maintenance instructions described in this manual.

Any other usage that is not described in this manual is considered unintended use. Unintended use includes but is not limited to the following actions:

- allowing unskilled personnel to perform any task on or with the equipment
- making changes to the equipment that have not been recommended or described in this manual or using parts that are not approved by TKH Airport Solutions.
- using materials or auxiliary equipment that are inappropriate or incompatible with TKH Airport Solutions equipment.
- failing to make sure that auxiliary equipment complies with approval agency requirements, local codes, and all applicable safety standards, provided that they are not in violation of national regulations

⚠ WARNING Using this equipment in ways other than described in the manual could result in serious injury or death and/or material damage.

The CEDD Inset Fixtures may only be used with CEDD system components approved by TKH Airport Solutions:

- CEDD Cable
- CEDD HPS Terminator
- CEDD HPS Basestation
- CEDD Master CMS
- CEDD Master AM

NOTICE

It is not allowed to connect the CEDD Fixtures to components other than approved CEDD components.

2.3 General safety rules

Become familiar with the general safety instructions in this section of the manual before installing, operating, maintaining or repairing this equipment.

- Make this manual available to personnel installing, operating, or maintaining this equipment.
- Only qualified personnel are allowed to install, operate or maintain this equipment (see *Qualified Personnel* on page 8).
- Always use the required personal protective equipment (PPE).
- Never look directly in the light source while the power is ON.
- Always follow safe electrical work practices.
- Follow all applicable safety procedures required by your company, industry standards and government or other regulatory agencies.
- Read all system component manuals before operating this equipment. A thorough understanding of system components and their operation will help you to operate the system safely and efficiently.
- Do not deactivate or bypass automatic safety interlocks or locked-out electrical disconnects.
- Protect equipment with safety devices as specified by applicable safety regulations.
- Use this equipment only in the environments for which it is rated.
- Never operate equipment with a known malfunction. If a malfunction occurs, turn the equipment OFF immediately.
- In any of the following cases the equipment must be taken out of service and locked away from unauthorized use. This is necessary:
 - If the housing or the electrical wiring is visibly damaged
 - If the housing or the electrical wiring has loose parts
 - If the equipment malfunctions
 - After excessive transportation stress (for example in damaged or defective packaging)

2.4 Electrical hazards



WARNING

- Never open the equipment while the power supply is switched ON.
- Never touch exposed electrical connections on this equipment while the power supply is switched ON.
- Do not attempt to operate or service electrical equipment if standing water is present.
- When working on the equipment always wear appropriate protective clothing.

2.5 Transport and Storage

Transport

- Use extreme care when moving heavy products. Verify that the moving equipment is rated to handle the weight. When loading or unloading, ensure that the products are carefully balanced and secured using a safety strap.
- Any products containing electronics must be stored and transported in conductive packing.

Storage

- If the equipment is stored before installation, it must be protected from the weather and kept free of condensation and dust.
- Keep the equipment in the original packing it was shipped in, until it is going to be installed.

3 About the product

3.1 About CEDD

CEDD is an innovative contactless energy and communication technology. Energy and data transport are combined in a two-wire cable system, a basestation, and contactless user points. With this structured cable concept, lighting on airfields can easily be installed or replaced without making electrical contact with the power or data cable.

The CEDD system has been specifically designed for the operation of Airfield Ground Lighting (AGL) systems on airports, with the highest possible reliability.

3.2 About the CEDD Inset Fixtures

All of the TKH Airport Solutions inset fixtures are available in CEDD. Refer to our website <http://www.tkh-airportsolutions.com> to see all the available variants of CEDD fixtures.

3.2.1 Position in the CEDD AGL System System

A typical CEDD AGL System System consists of a CEDD HPS Basestation that provides power to the CEDD AGL System LED fixtures and bi-directional communication to all the CEDD AGL System LED fixtures connected to the CEDD cable. A CEDD HPS Terminator matches the correct characteristic impedance of the CEDD cable with the connected CEDD AGL System LED fixtures.

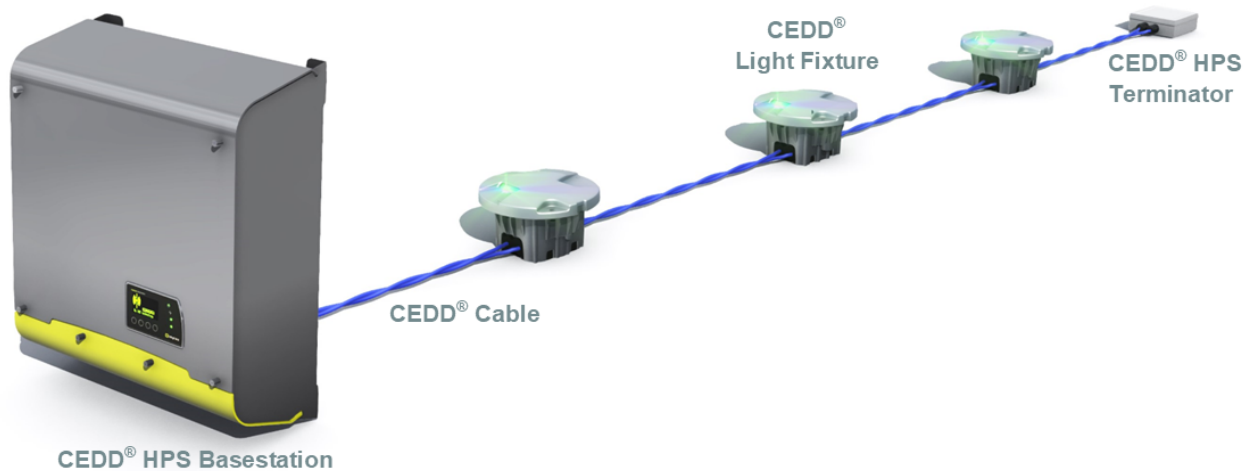

3.2.2 CEDD Inset Fixtures: Parts

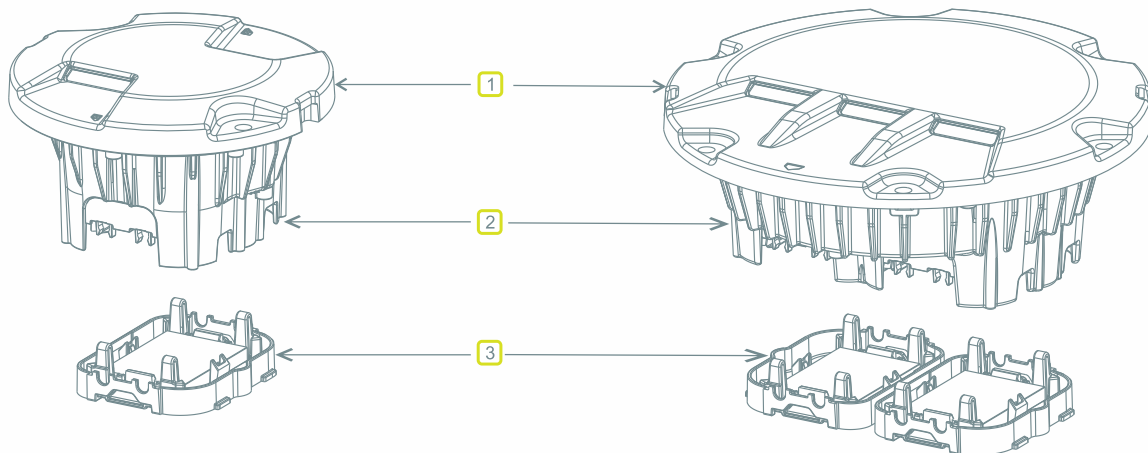

CEDD 8" inset fixture

CEDD 12" inset fixture

1. Cover
2. Housing
3. Inductive clamp lid

3.2.3 Specifications

Refer to the datasheet of your fixture to read the specifications of the product.

<http://www.tkh-airportsolutions.com/airfield-products>

3.2.4 Spare Parts

Spare parts for CEDD Inset Fixtures

Pos.	Name	Order code
1a	Glass dome	200.833-007
1b	Flat gasket for glass dome	230.063-017
2a	LED module A white	
2b	LED module B white	
2c	LED module A yellow	
2d	LED module B yellow	
2g	LED module A green	
2h	LED module B green	
2e	LED module A red	
2f	LED module B red	
3a	Silica gel bag	P-650140
3b	Cover for silica bag	230.274-00
4	Plastic ring for dome	230.066-017
5	Heat sink/Electronic Driver	201.150-10
6	Breakable coupling type C (CEDD)	790902/2

For information about spare parts for the CEDD Elevated Base please contact the TKH Airport Solutions Customer Service team at service@tkh-airportsolutions.com.

4 Inspection

Inspect the transport box

Before installation, the transport box and CEDD fixture must be inspected for damage and defects. If the transport box appears to be damaged, keep the transport box and cushioning material until the contents of the box have been checked for completeness and the CEDD fixture is checked mechanically and electrically.

NOTICE If the CEDD fixture has been damaged during transport, put the product and all other parts back into the transport box and contact your shipper and carrier.

Inspect the contents of the transport box

The transport box must contain the following items:

- **8 inch inset fixture:**
 - Light fixture, complete with I-plate and inductive clamp with lid
 - O-ring
- **12 inch inset fixture:**
 - Light fixture, complete with I-plate and inductive clamp with lid

Inspect the contents of the transport box. If any item is missing, contact TKH Airport Solutions Customer Service.

Visually inspect the CEDD Fixture

Unpack and inspect the CEDD fixture. If there is any mechanical damage or defect, contact TKH Airport Solutions Customer Service.

5 Installation

- ⚠ WARNING**
- Before you begin working on the CEDD Inset Fixtures, you must make sure that AC mains power and Logic AC mains power of the CEDD HPS Basestation have been shut off. The circuit breakers must be in the OFF position
 - Wait a minimum of 15 minutes for the system to de-energize.

5.1 Tools and materials needed

- A clean, flat working surface
- A bag to collect any debris removed from the shallow base
- Non-caustic cleaning agent
- Calibrated torque wrench
- M10 bolts and washers (as supplied with the shallow base)
- Hex socket (17 mm)
- If installing an 8" fixture into a 12" shallow base:
 - a CEDD adapter ring 8"/12"
 - a new O-ring for the 12" shallow base (order code P-850372)

5.2 Installing a CEDD 8" fixture in an 8" shallow base

To install the CEDD 8" fixture in a shallow base, follow the steps below.

NOTICE When mounting this fixture in a 12" shallow base a CEDD adapter ring 8"/12" is needed. See *Installing a CEDD 8" fixture in a 12" shallow base* on page 18.

1. Remove any debris, leaves etc. from the shallow base and collect them in a bag. No material may be left inside the shallow base. Clear the inner rim of sand and dust. Clean the inside of the shallow base using a non-caustic cleaning agent.

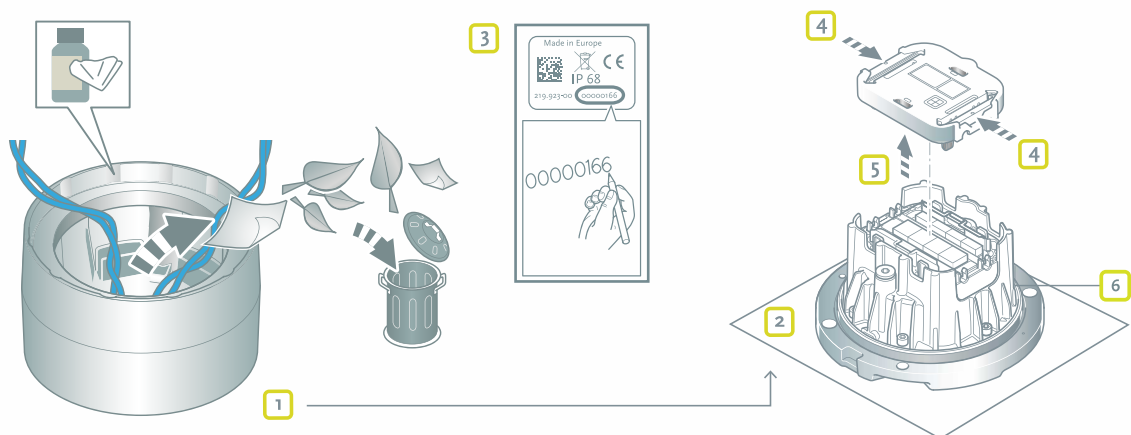

2. Remove the fixture from its packaging and carefully put it upside down on a clean, flat working surface.

- Record the NUID of the fixture (see the QR-code on the sticker) and its aeronautical name.

NOTICE Information about NUIDs and their related aeronautical names is vital for commissioning and operation of the CEDD AGL System system.

- Unlock the CEDD inductive clamp by pressing the two flanges on both sides inwards.
- Lift the inductive clamp lid with small tilting movements and remove it.
- Make sure the O-ring is properly seated in the groove in the top cover of the 8" fixture.
- Align the CEDD cables with the two slots and click these into the small clamps on both sides.

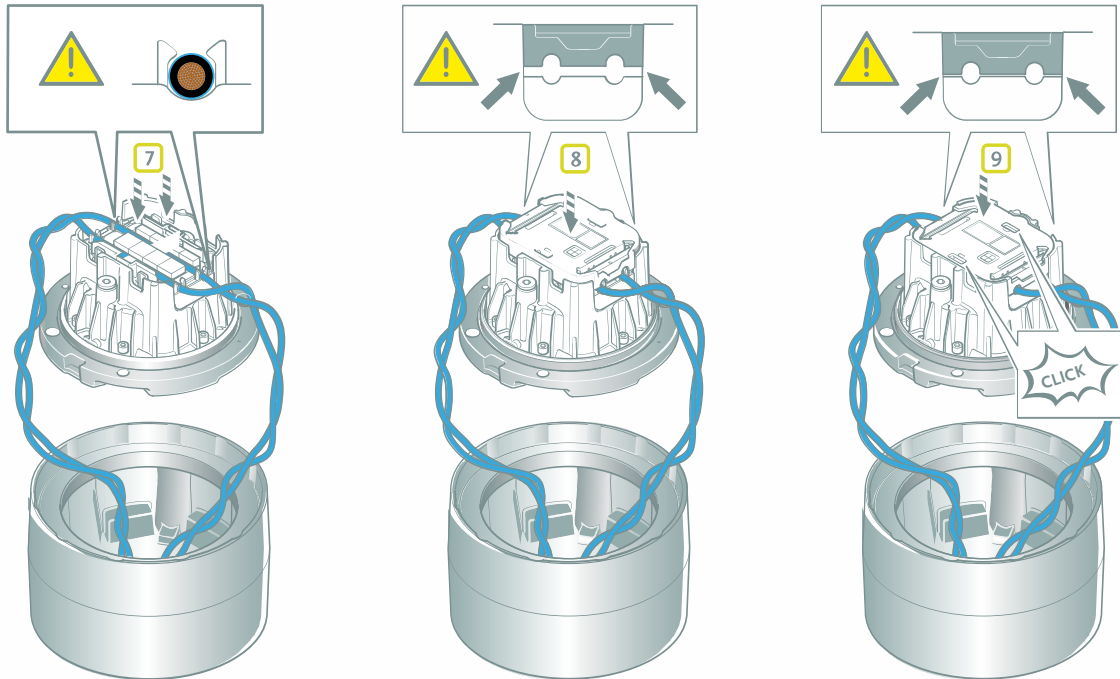

- Reposition the inductive clamp lid.

NOTICE The inductive clamp lid only fits in one way. The rounded notch on one side and the plastic retention protrusions make sure of this.

- Firmly push down the inductive clamp lid until you hear the metal retention brackets click into place.

NOTICE Do not apply excessive force on the inductive clamp lid, as this could damage the fixture.

- Verify that the two metal retention brackets are visible and aligned straight with the CEDD inductive clamp.

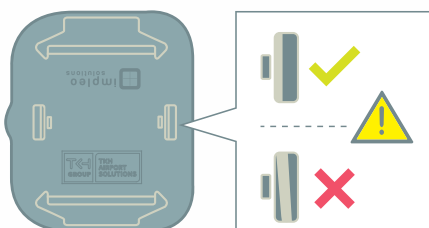

- Turn the fixture the right way up and guide the fixture and cables into the shallow base.

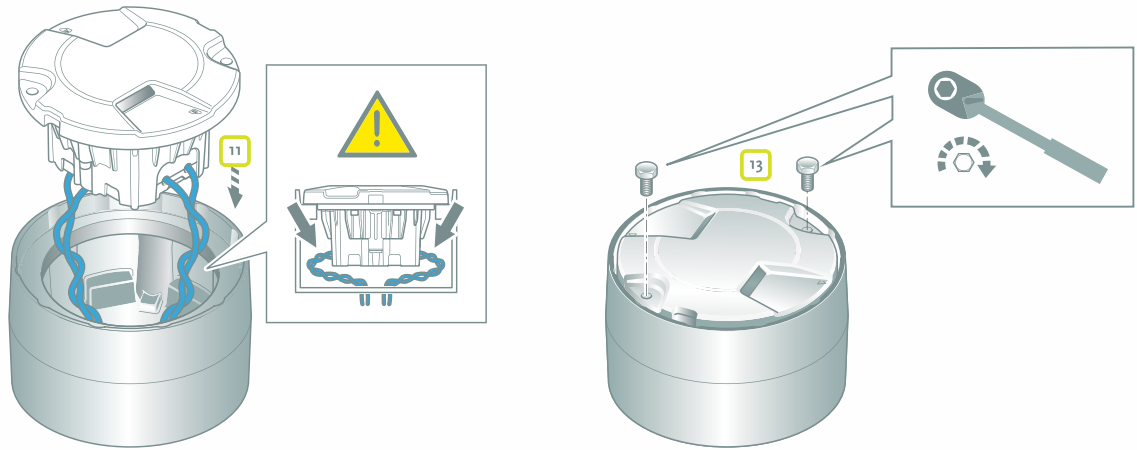

12. Make sure the fixture is placed in the correct direction by aligning the A and B sides with the markings in the shallow base.

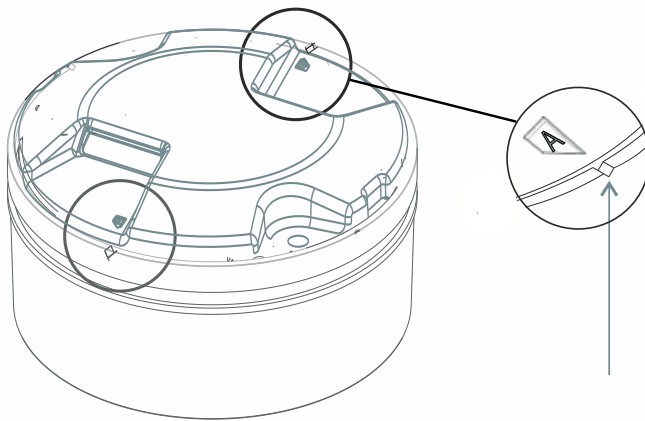

NOTICE Before bolting the fixture cover to the shallow base, it is important to make sure the O-ring is properly seated in the groove to ensure the seal is watertight.

13. Mount the fixture onto the shallow base with 2 bolts and washers. Tighten the bolts using a calibrated torque wrench to the torque value given in the shallow base installation instructions.

5.3 Installing a CEDD 8" fixture in a 12" shallow base

Tools and materials needed:

- One CEDD adapter ring 8"/12"



- A new O-ring for the 12" shallow base (order code P-850372)

To install the CEDD 8" fixture in a 12" shallow base, follow the steps below.

NOTICE When installing or replacing a fixture in an existing shallow base, always use a new O-ring.

1. Remove any debris, leaves etc. from the shallow base and collect them in a bag. No material may be left inside the shallow base. Clear the inner rim of sand and dust. Clean the inside of the shallow base using a non-caustic cleaning agent.
2. To install the CEDD adapter ring 8"/12" in a 12" shallow base:
 - a. Place the O-ring into the designated groove of the shallow base.
 - b. Place the CEDD adapter ring 8"/12" in the shallow base.
 - c. Mount the CEDD adapter ring 8"/12" onto the shallow base with 6 bolts and washers.
 - d. Fasten bolts 1 to 6 by hand in the following crosswise pattern:

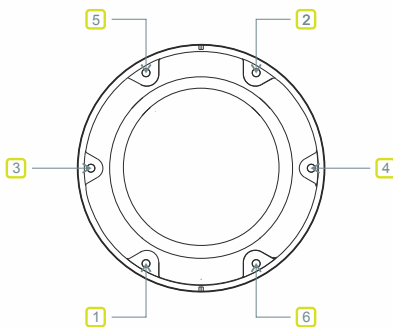

- e. Tighten bolts in the same pattern with the calibrated torque wrench (to the torque values given in the shallow base installation instructions).
3. To complete the installation of the CEDD 8" fixture, go to *Installing a CEDD 8" fixture in an 8" shallow base* on page 15 and follow steps 2 to 13.

5.4 Installing a CEDD 12" fixture in a 12" shallow base

To install the CEDD 12" fixture in a shallow base, follow the steps below.

1. Remove any debris, leaves etc. from the shallow base and collect the waste material in a bag. No material may be left inside the shallow base. Clear any sand or dust from the groove under the O-ring. Clean the inside of the shallow base, including the groove, using a non-caustic cleaning agent.

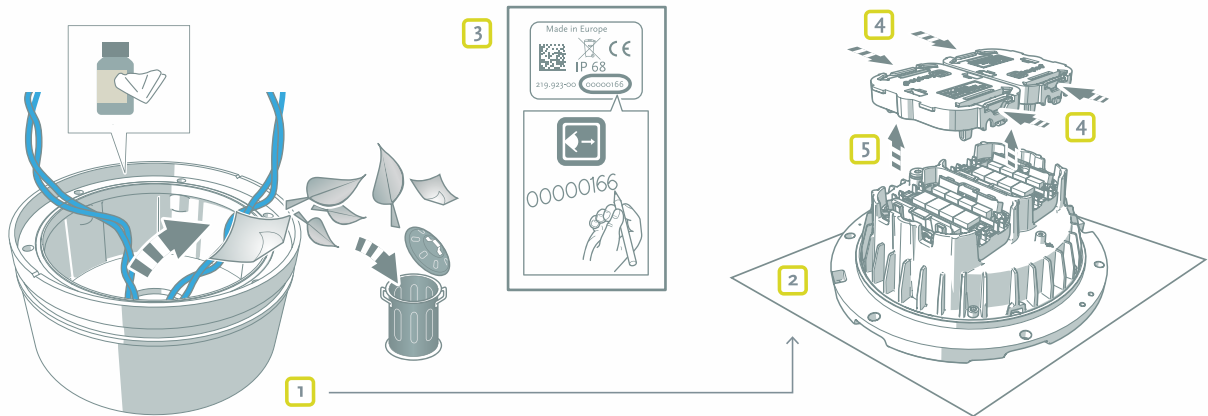

2. Remove the fixture from its packaging and carefully put it upside down on a clean, flat working surface.
3. Record the NUID of the fixture (see the QR-code on the sticker) and its aeronautical name.

NOTICE Information about NUIDs and their related aeronautical names is vital for commissioning and operation of the CEDD AGL System system.

4. Unlock the CEDD inductive clamp by pressing the two flanges on both sides inwards.
5. Lift the inductive clamp lid with small tilting movements and remove it.
6. Make sure the O-ring is properly seated in the designated groove of the 12" shallow base.
7. Align the CEDD cables with the two slots and click these into the small clamps on both sides. In each inductive clamp, the 2 cables must be routed through the slots in opposite directions:

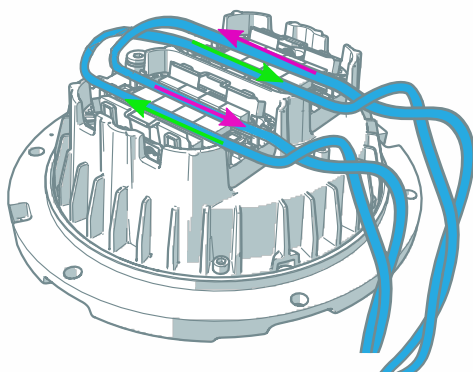

8. Reposition the CEDD inductive clamp lid.

NOTICE The inductive clamp lid only fits in one way. The rounded notch on one side and the plastic retention protrusions make sure of this.

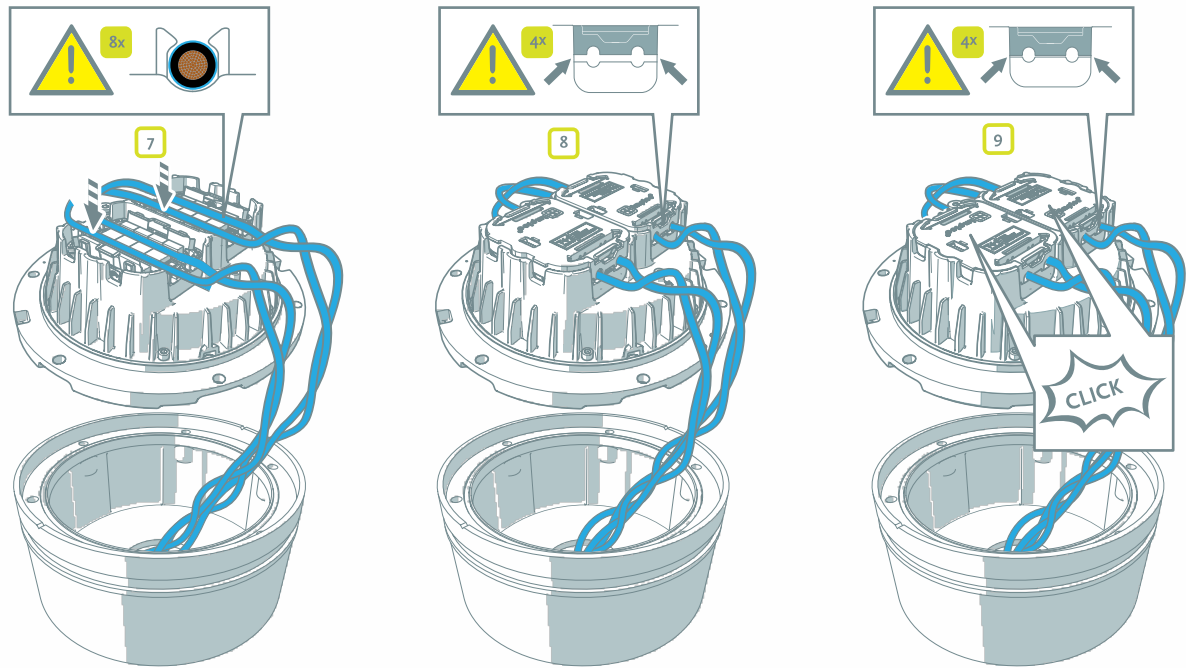

9. Firmly push down the inductive clamp lid until you hear the metal retention brackets click into place.

NOTICE Do not apply excessive force on the inductive clamp lid, as this could damage the fixture.

10. Verify that the two metal retention brackets are visible and aligned straight with the CEDD inductive clamp.

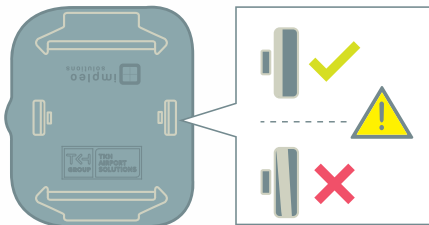

11. Turn the fixture the right way up and guide the fixture and cables into the shallow base.

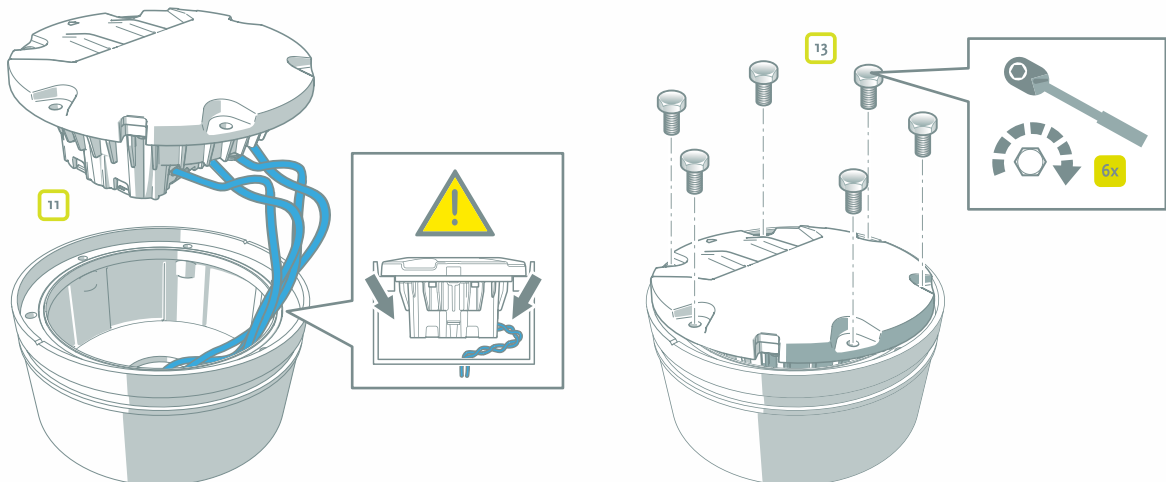

12. Make sure the fixture is placed in the correct direction by aligning the A and B sides with the markings in the shallow base.

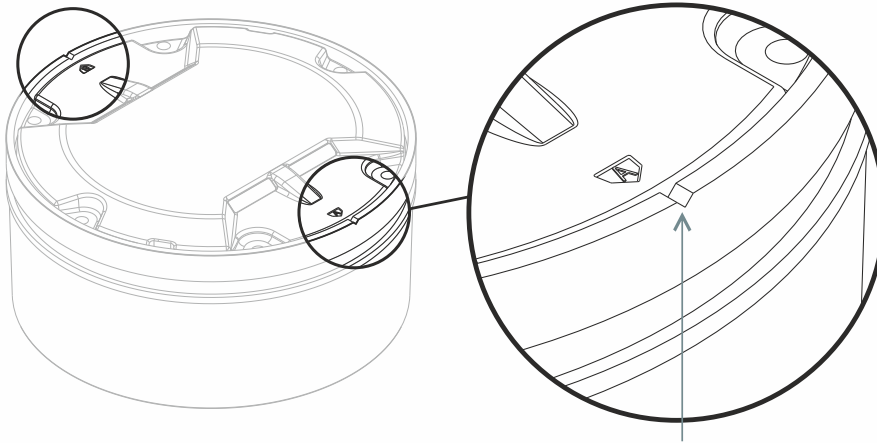

13. Mount the fixture onto the 12" shallow base with 6 bolts and washers.
- a. Fasten bolts 1 to 6 by hand in the following crosswise pattern:

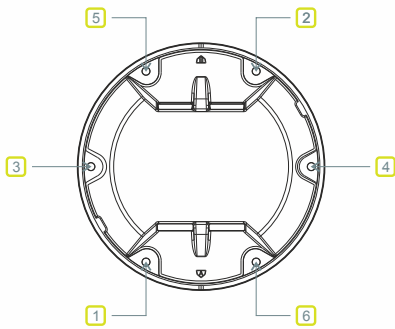

- b. Tighten bolts in the same pattern using a calibrated torque wrench (to the torque value given in the shallow base installation instructions).

5.5 Checking the installation

Visually inspect the CEDD fixture after installation to check that:

- the top cover is undamaged
- all bolts are secure

6 Operation and Commissioning

After completing the installation, the CEDD fixtures may be commissioned. A complete list of all NUIDs and related aeronautical names is required for commissioning.

Refer to the applicable Operating and Commissioning manual for information on the commissioning procedure for the project.

7 Maintenance

Before you begin read these warnings carefully.

- ⚠ WARNING** • Before you begin working on the CEDD Inset Fixtures, you must make sure that AC mains power and Logic AC mains power of the CEDD HPS Basestation have been shut off. The circuit breakers must be in the OFF position
- Wait a minimum of 15 minutes for the system to de-energize.

- ⚠ WARNING** • Only trained and qualified personnel is allowed to maintain the equipment.
- Replace malfunctioning components according to the instructions provided in this manual.

7.1 Preventive maintenance

Due to the contactless CEDD technology, minimal preventive maintenance is required. Apart from normal airfield cleaning procedures, perform regular visual inspections of the exterior of the CEDD fixture.

Maintenance frequency depends on the conditions under which the runway is used (climate, traffic, etc.). Contact TKH Airport Solutions Customer Service if extreme local conditions demand additional maintenance. The recommended practices for maintenance are described in the FAA advisory circular No.AC150/5340-26 and in the ICAO Aerodrome Design Manual, Part 9 Airport Maintenance Practices.

7.2 Corrective maintenance

When it is necessary to replace or repair malfunctioning components the whole light fixture should be de-installed and returned to TKH Airport Solutions Customer Service.

To de-install the CEDD Inset Fixtures, follow the instructions in section *De-installing a CEDD 8" fixture* on page 24 or section *De-installing a CEDD 12" fixture* on page 25.

7.2.1 Tools and materials needed

The following standard tools and accessories are required for de-installation of the fixture:

- Hex socket (for example 17 mm)
- Lifting tool for removing the fixture from the shallow base (Order code 302312)

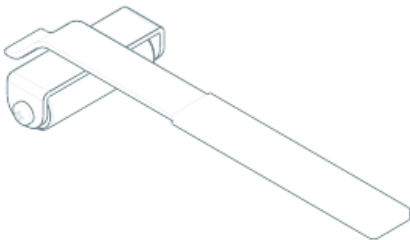

- Calibrated torque wrench
- Optional – a suitable blind plate to fit the shallow base

7.2.2 De-installing a CEDD 8" fixture

To remove the CEDD 8" fixture from a shallow base, follow the steps below.

1. Remove the bolts using a Hex socket.

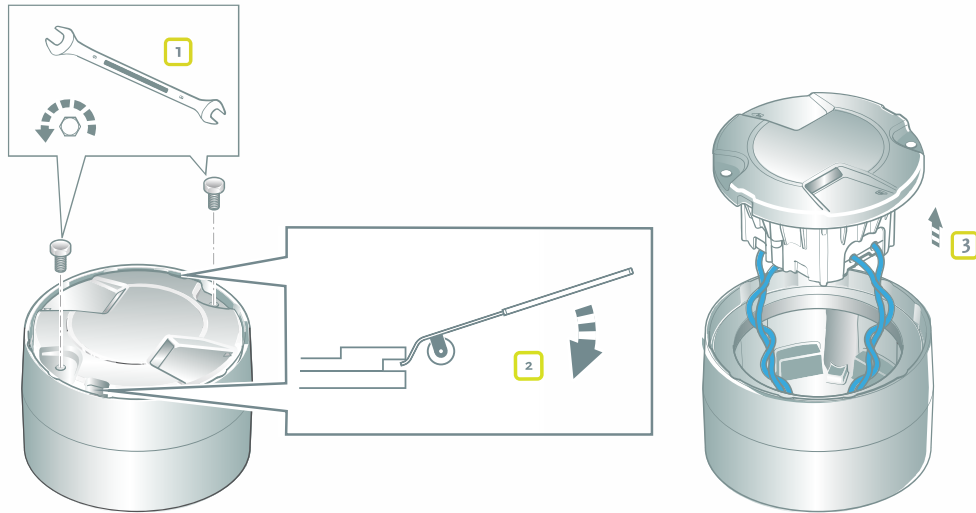

2. Pry the fixture out of the shallow base using the lifting tool.
3. Lift the fixture and turn it upside down.
4. Release the CEDD inductive clamp by pressing the two flanges on both sides inwards.

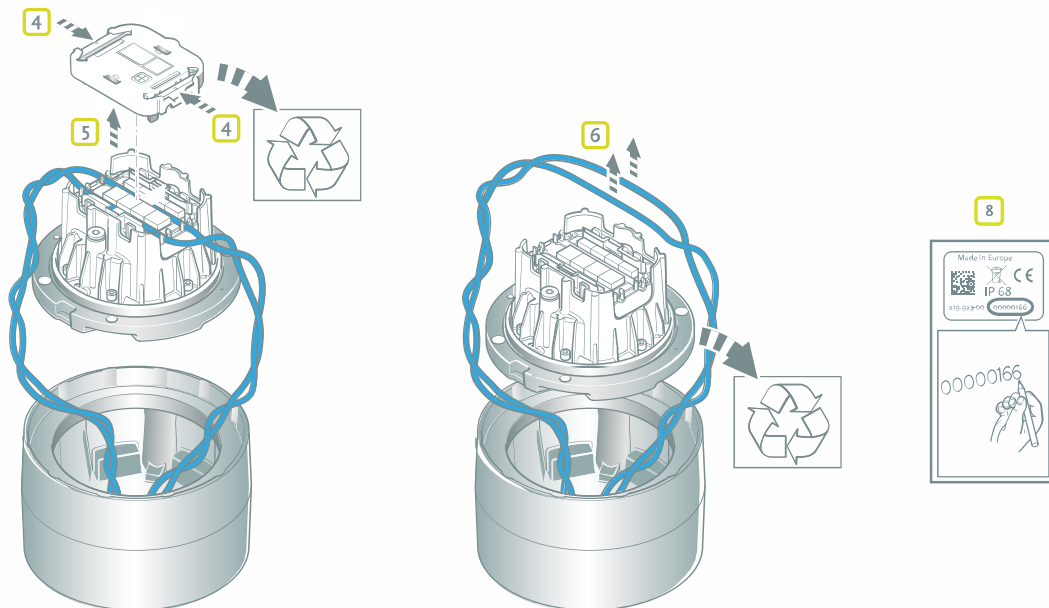

5. Lift the CEDD inductive clamp lid with small tilting movements and remove it.
6. Take the cables from the slots and remove the fixture.
7. If the fixture will not be replaced immediately, fix a suitable blind plate over the shallow base.
8. Record the NUID of the fixture (see the QR-code on the sticker) and its aeronautical name.

NOTICE Information about NUIDs and their related aeronautical names is vital for commissioning and operation of the CEDD AGL System system.

7.2.3 De-installing a CEDD 12" fixture

To remove the CEDD 12" fixture from a shallow base, follow the steps below.

1. Remove the bolts in a crosswise pattern from 6 to 1 using a Hex socket.

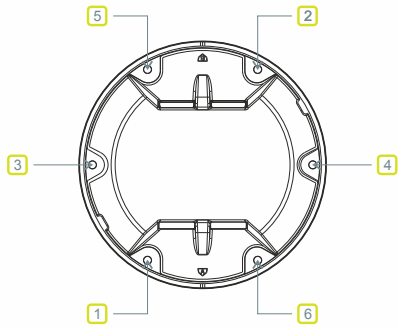

2. Pry the fixture out of the shallow base using the lifting tool.

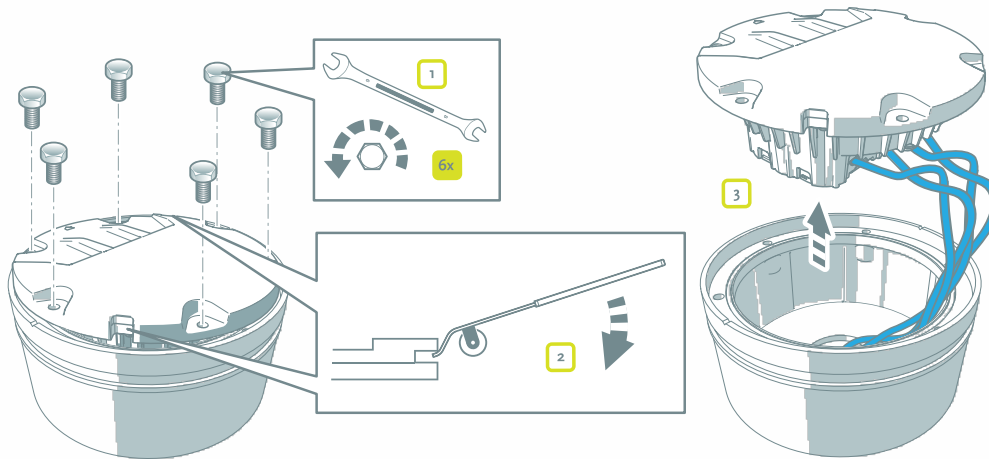

3. Lift the fixture and turn it upside down.
4. Release the CEDD inductive clamp by pressing the two flanges on both sides inwards.

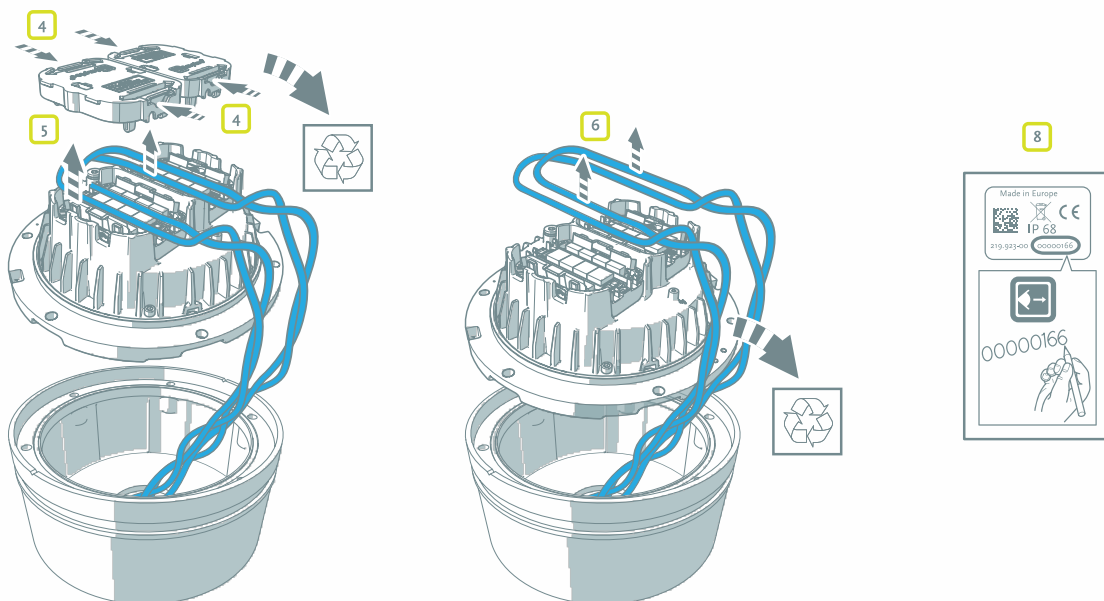

5. Lift the CEDD inductive clamp lid with small tilting movements and remove it.
6. Take the cables from the slots and remove the fixture.
7. If the fixture will not be replaced immediately, fix a suitable blind plate over the shallow base.
8. Record the NUID of the fixture (see the QR-code on the sticker) and its aeronautical name.

NOTICE

Information about NUIDs and their related aeronautical names is vital for commissioning and operation of the CEDD AGL System system.

8 Troubleshooting

This chapter describes how to diagnose the most common problems with the CEDD Inset Fixtures and their corrective actions. For software and communication problems, see the applicable Operating and Commissioning manual.

- ⚠ WARNING**
- Before you begin working on the CEDD Inset Fixtures, you must make sure that AC mains power and Logic AC mains power of the CEDD HPS Basestation have been shut off. The circuit breakers must be in the OFF position
 - Wait a minimum of 15 minutes for the system to de-energize.

If a fixture is not working correctly do the following checks to diagnose the problem:

1. Fixture check
2. CEDD® cable check
3. Ferrites and clamp check

If the fixture is still not working after these checks, contact TKH Airport Solutions.

8.1 Visual fixture check

This procedure describes how to check whether the fixture has exterior damage.

1. Check that there are no cracks in the fixture top cover.
2. Check that the rubber seal around the lens is intact.
3. Check that the lens is not obscured with rubber or grease. If necessary, clean the lens.

8.2 CEDD cable check

This procedure describes how to make sure that the CEDD cables are undamaged and correctly placed in the fixture.

1. Remove the fixture from the shallow base (see *De-installing a CEDD 8" fixture* on page 24 or *De-installing a CEDD 12" fixture* on page 25).
2. Turn the fixture upside down and unlock the CEDD® inductive clamp lid by pressing the two flanges on both sides inwards. Lift the inductive clamp lid and remove it.
3. Check for physical damage to the cables
4. Check that the cables can move freely in the slots.
5. For a 12" fixture, make sure that the cables are inserted in the right slots:

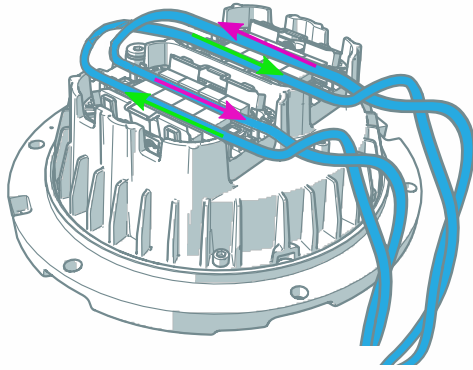

8.3 Ferrites and clamp check

This procedure describes how to determine whether the problem is caused by an open clamp or by damaged ferrite parts.

1. Make sure that the clamp is closed.

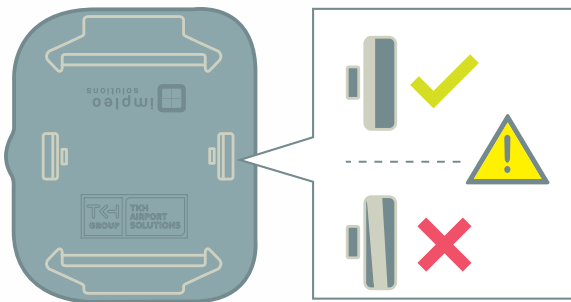

If the clamp is not closed or the metal retention brackets are not positioned correctly, go to step 7.

2. Remove the CEDD inductive clamp lid and both CEDD cable wires.
 - a. Check for mechanical damage to the clamps
 - b. Check that the metal spring in the clamp is working
3. Inspect the I-plate of the clamp.

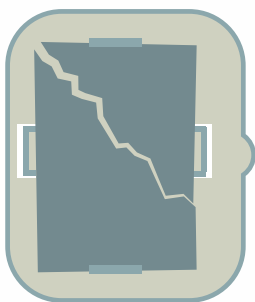

If the I-plate is damaged (chipped or broken) it needs to be replaced. Go to step 7..

4. Inspect each individual E-core of the unit.

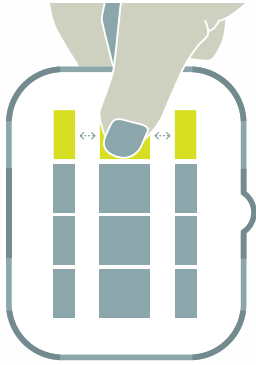

- a. Remove any ferrite debris
- b. Remove any grease or oil on the E-core surfaces
- c. Check that there are no cracks or gaps between the blocks
- d. Press down on each center block in turn - the corresponding side blocks should lower at the same time
If the E-core is damaged, go to step 7.

5. Reposition the cables in the cable clips.
6. Close the clamp and make sure that the metal retention brackets are positioned correctly. See *Installing a CEDD 8" fixture in an 8" shallow base* on page 15 or *Installing a CEDD 12" fixture in a 12" shallow base* on page 19.
7. If the fixture is still not working correctly, contact TKH Airport Solutions.

9 Taking out of service

1. De-install the fixture as described in *De-installing a CEDD 8" fixture* on page 24 or *De-installing a CEDD 12" fixture* on page 25).
2. Return the fixture to TKH Airport Solutions for maintenance, repair or disposal. Contact TKH Airport Solutions Customer Service for the correct address.

9.1 Disposal

All electrical and electronic products must be disposed of separately from normal waste at the end of their useful life.



Company profile:

TKH Airport Solutions offers a complete range of LED-based airfield ground lighting products that are designed to be easy to install, operate, and maintain, and are compliant with international aviation standards. Our products meet the needs of our customers and contribute to a better future for the aviation industry. Being part of the TKH Group, our company can build on a history of more than 90 years in smart connectivity, energy distribution and AGL.

More information:

TKH Airport Solutions
sales@tkh-airportsolutions.com
www.tkh-airportsolutions.com
+31 (0)53 57 414 56

Visiting address:

Elektrostraat 17
7483 PG Haaksbergen
The Netherlands